

ACOUSTIX POD

All booths should be accessible 

All booths should have sprinkler access 



ACOUSTIX POD

Workstation's ACOUSTIX Pod is the first portable acoustic office booth designed specifically for wheelchair access and the only booth compliant with building fire sprinkler requirements.

We understand that your employee's health and safety in the new "normal" COVID-19 environment is a top priority and it's ours too. ACOUSTIX Pod has a dual fan circular airflow system designed to maximise air exchange rates and to create gentle airflow within the booth. Optional HEPA Filter.

The ACOUSTIX Pod is an innovative Australian Registered Design and manufactured locally and available in your choice of finishes.

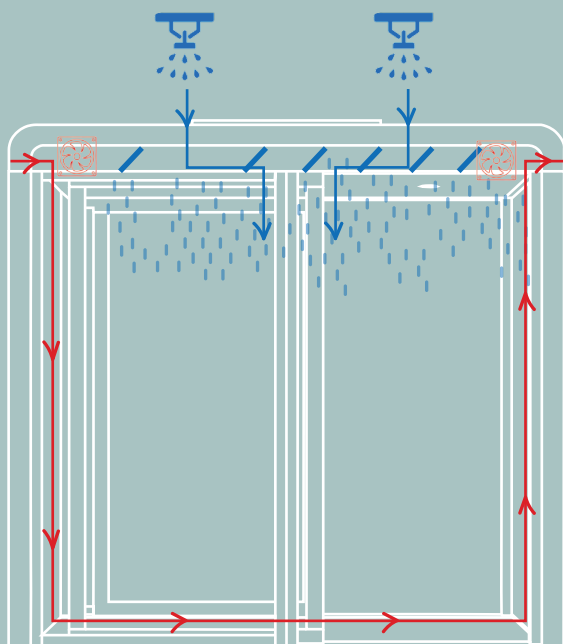

*Circular air flow system & fire sprinkler access



Wheelchair access sliding door (DDA)

No imported booth is compliant with the Disability Discrimination Act, without adding a ramp and Fire Compliance Regulation and are therefore illegal to install in multi-storey buildings.

Workstation's ACOUSTIX Pod is wheelchair accessible, utilises a soft close sliding door and has accessible handles for all users.

The ACOUSTIX Pod is the only acoustic booth system designed specifically for use in compliance with building fire sprinkler requirements in multi-storey buildings.

The special roofing design of the ACOUSTIX Pod is designed to enable sprinkler water-flow, without special plumbing.

ACOUSTIX Pod is the only booth with the option to be fitted to the building's air conditioning ducts.

FEATURES

FEATURES	STANDARD	OPTIONAL	IMPORT
Soft touch sliding door for wheelchair access	.		
No step up floor	.		
Sprinkler permeable ceiling design	.		
Easy access cabling panels	.		.
Motion activated power	.		.
LED lighting	.		.
GPO and USB power	.		.
AV panel ready	.		
Multi fan circular airflow system	.		
White board panel	.		
Customer fabric choices	.		
Easy clean Acoustix Medipod interior walls		.	
High acoustic rated solid panels	.		.
Hinged door on single person booth	.		.
Height adjustable tables or desks		.	
Clean room		.	
Integrated ergonomic lounges		.	
Philips HEPA filter airflow system		.	
Acoustic glass	.		.
Double glazing door noise suppression	.		
Electric door		.	

Whiteboard side panels



Easy access for your IT needs



Easy set up & relocation



DETAILS

Beautiful perforated roof treatment for acoustic control and sprinkler access

FIRE SPRINKLER ACCESSIBLE
Roofing designed to enable sprinkler water-flow for multi-storey buildings

USABLE WHITEBOARD END PANELS

WINDOW PRIVACY & DECALS
OPTIONAL

ACOUSTIC PANELS
Walls tested to 27% decibel reduction

OPTION TO CONNECT TO DUCTED AIR

EASY RECONFIGURATION
Easy reconfiguration and relocation

MEDI POD OPTION

Clean wall wipe down interior for optimal infection control

SOFT CLOSE WHEELCHAIR ACCESSIBLE SLIDING DOOR

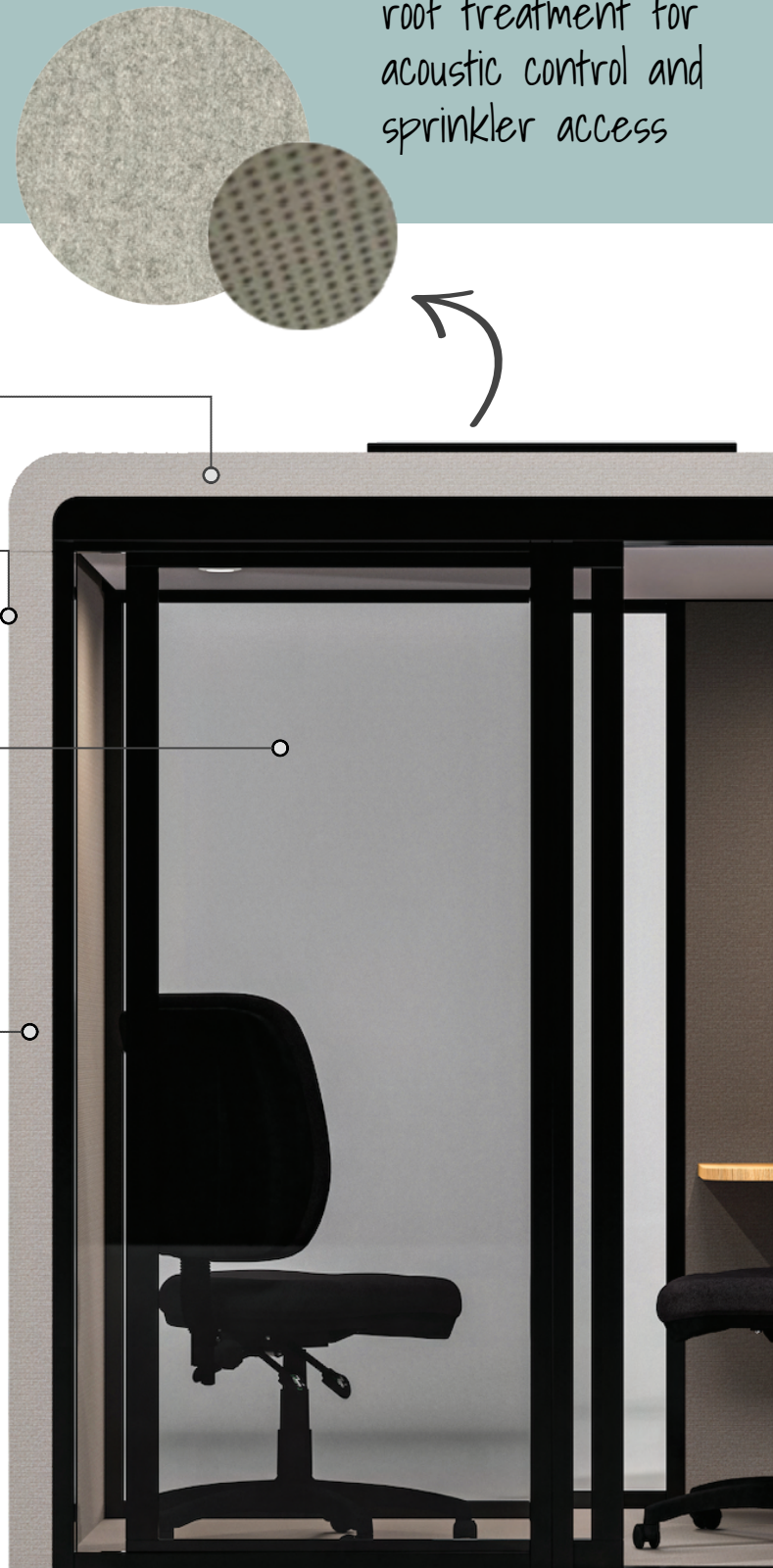

Cloth panel choices

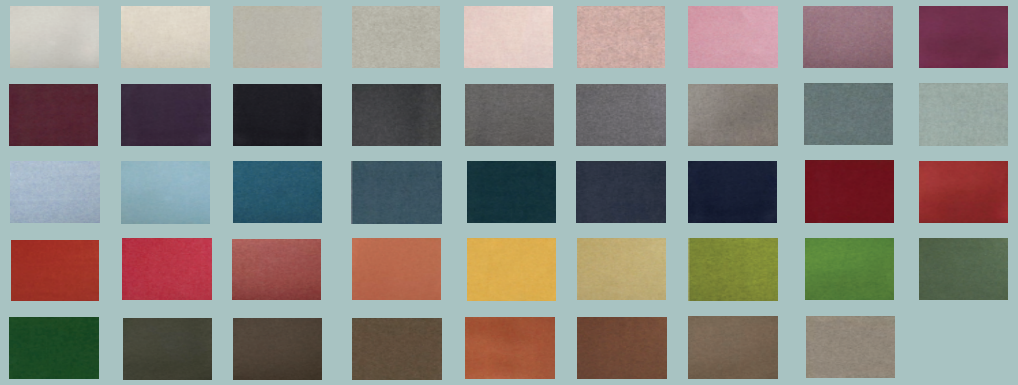

SENSOR ACTIVATED LIGHTS

CIRCULAR AIRFLOW SYSTEM

Circular air intake system brings in office air. Design stimulates draw through and natural convection, while dual ceiling mounted fans maximise air exchange. Two air system models: standard two motor system or premium integrated Phillips TM HEPA filter system (optional)

INTEGRATED POWER

2 x GP and USB A & USB C, HDMI cabling and data (CAT6, CATa6, CAT7) All are ready made to attach and all have power access and panel configuration for attachment of wall mounted TV and monitors

EASY ACCESS POWERWALL PANELS

Allows your IT department to run and connect any cabling in walls and ceilings. The quick release panel system gives your team full flexibility

Optional lounges or sit-stand desks



SIZES

Two Person ACOUSTIX Pod

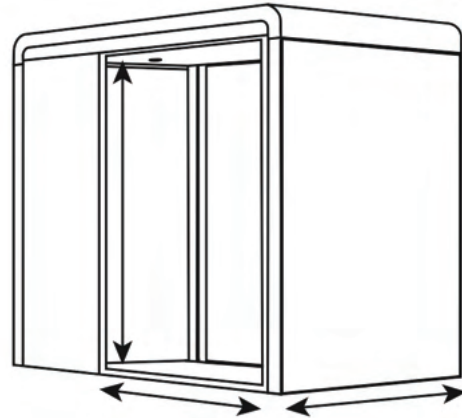
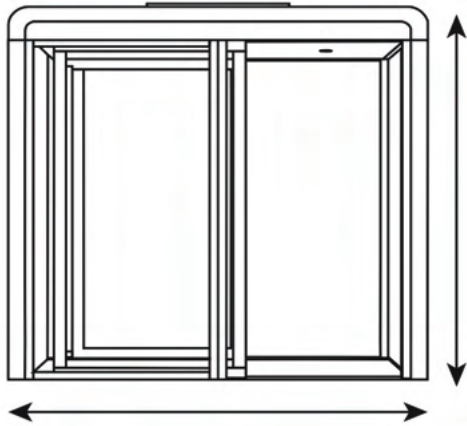

TWO PERSON ACOUSTIX POD DIMENSIONS

Booth Width (external)	2250 mm
Booth Height (external)	2150 mm
Booth Depth (external)	1230 mm
Booth Width (internal)	2080 mm
Booth Height (internal)	2020 mm
Booth Depth (internal)	1100 mm
Door Width	880 mm
Door Height	2020 mm

Four Person ACOUSTIX Pod

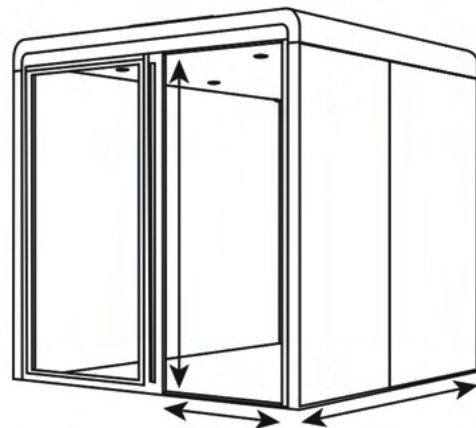
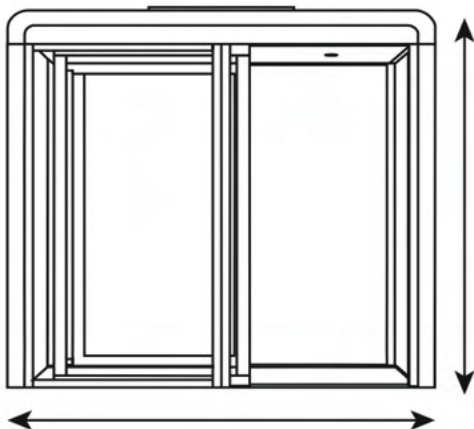

FOUR PERSON ACOUSTIX POD DIMENSIONS

Booth Width (external)	2250 mm
Booth Height (external)	2150 mm
Booth Depth (external)	2430 mm
Booth Width (internal)	2080 mm
Booth Height (internal)	2020 mm
Booth Depth (internal)	2300 mm
Door Width	880 mm
Door Height	2020 mm

Six Person ACOUSTIX Pod

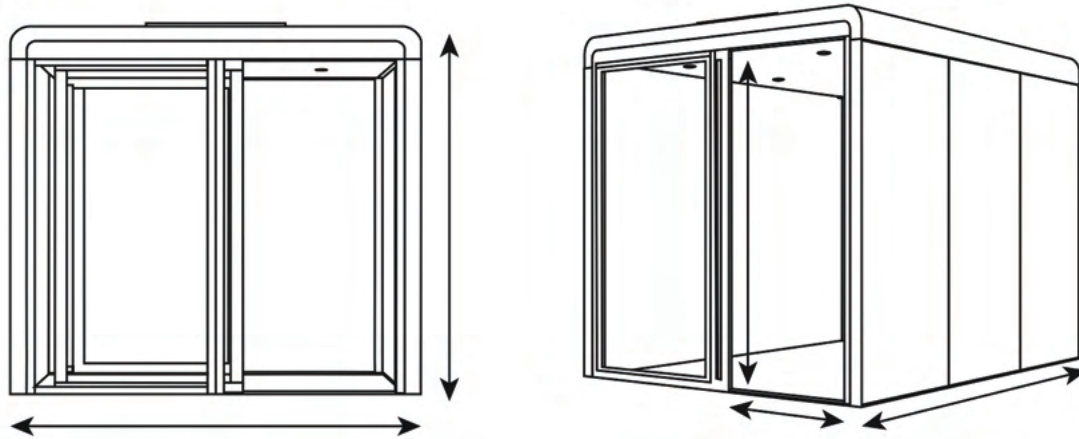

SIX PERSON ACOUSTIX POD DIMENSIONS	
Booth Width (external)	2250 mm
Booth Height (external)	2150 mm
Booth Depth (external)	3630 mm
Booth Width (internal)	2080 mm
Booth Height (internal)	2020 mm
Booth Depth (internal)	3500 mm
Door Width	880 mm
Door Height	2020 mm

The ACOUSTIX Pod is the only genuine Australian made, wheelchair and fire sprinkler accessible booth solution. Custom sizing is available.



The ACOUSTIX **MEDI** Pod range features easy wipe down internal surfaces for infection control. This range similarly comes in two, four and six person options. Custom sizing is available to suit all hospital and medical application needs.





WORKSTATIONS.COM.AU

15 Queen Street,
Melbourne, VIC 3000

74 Yass Road,
Queanbeyan, (ACT) 2620

Level 10, 387 George Street,
Sydney, NSW 2000

02 9319 4107
sales@workstations.com.au
www.workstations.com.au

Find out more here

<https://gregorychairs.com.au/acoustix/>

